

SAFETY  
WITHOUT  
COMPROMISE

**PIN-TECH™**

## Bubble-Tight <500 ppm Pressure Relief Vent



**PROTECTOSEAL**

**SERIES  
56000**

- Reduce fugitive emissions of volatile organic compounds (VOC's) and other hazardous materials
- Sizes 2" (DN 50) through 24" (DN 600)
- End-of-line pressure, end-of-line vacuum, and in-line (pipe-away) configurations
- Full open at set point
- Easy to reset after opening
- Reduced maintenance costs

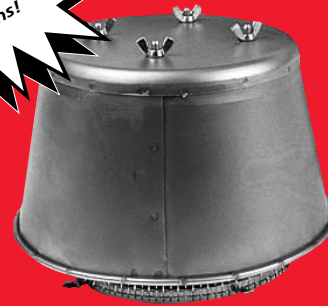

Series 56000, PIN-TECH Pressure Relief Vents are designed and tested to address concerns about the leakage of fugitive emissions prior to set point.

PIN-TECH vents are mounted to the vapor space flange connection of a storage tank or vessel. The vents utilize a unique technology that employs a buckling pin to hold the vent piston closed (Fig. 1) with less than 500 ppm leakage up to the relief set point. The pin is an accurately machined, straight metal rod. The force required to buckle the pin is governed by Euler's Law and is a function of the pin's metallurgy, length and diameter. When the pressure in the tank reaches the vent set point, the axial force is sufficient to buckle the pin and the vent sealing piston is allowed to move to its full open, relieving position (Fig. 2). The pin buckles completely and instantaneously.

### **DIRECT ACTING CONFIGURATION**

In the PIN-TECH "direct acting" design, tank pressure acts on the sealing area of the piston and generates a force that is transmitted to the pin. The vent set point is reached when the developed axial force is sufficient to buckle the pin.



Fig. 1 PIN-TECH Pressure Relief Vent in the closed, bubble-tight position



Fig. 2 PIN-TECH Pressure Relief Vent in the full open, full flow position

### **ENVIRONMENTAL REGULATIONS**

Protectoseal's PIN-TECH vents provide a means of complying with the stringent VOC emission requirements mandated by the United States Environmental Protection Agency (EPA) while maintaining the highest level of safety in storage facility operations. National standards of performance referencing leakage of hazardous materials from storage tanks and restricting fugitive emissions from equipment can be met. Among the most significant of these standards, as outlined in Title 40 of the Code of Federal Regulations (CFR) are:

- **Part 60 Subpart K:** Standards of Performance for Storage Vessels for Petroleum Liquid
- **Part 60, Subpart Ka:** Standards of Performance for Storage Vessels for Petroleum Liquid
- **Part 60, Subpart Kb:** Standards of Performance for Storage Vessels for Volatile Organic Liquid Storage Vessels (including Petroleum Liquid Storage Vessels)
- **Part 60, Subpart VV:** Standards of Performance for Equipment Leaks of VOC in the Synthetic Organic Chemical Manufacturing Industry
- **Part 60, Subpart GGG:** Standards of Performance for Equipment Leaks of VOC in Petroleum Refineries

### **\*ETV VERIFICATION**

ETV has officially verified that PIN-TECH Pressure / Vacuum Relief Vents allow "no detectable" emissions (<500 ppm) from low-pressure storage tanks that contain Volatile Organic Compounds (VOC's). The U.S. Environmental Protection Agency (EPA) and South Research Institute operate the Environmental Testing Verification (ETV) program to verify the performance of technical solutions to environmental problems. Copies of the report are available from Protectoseal upon request.

## Direct Acting Vent Configuration

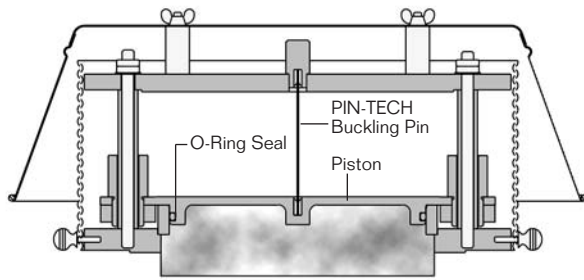

**Piston In Closed Position**  
(Tank Pressure < Set Pressure)

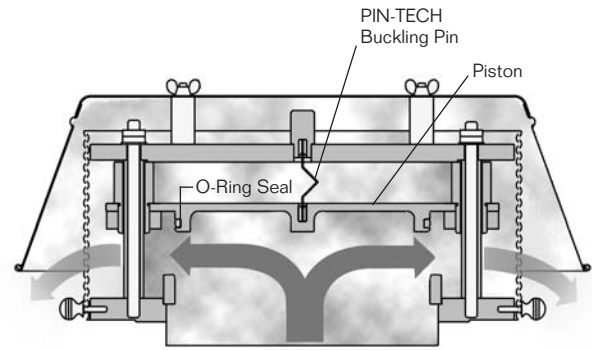

**Piston In Open Flowing Position**  
(Tank Pressure > Set Pressure)

**Construction:** PIN-TECH is offered in a comprehensive range of metals to withstand the corrosive action of vapors and atmospheric conditions.

- All Stainless Steel
- Stainless Steel with Steel Flange & Hood
- All Alloy C / C276
- Stainless Steel with Steel Flange & Aluminum Hood

**Buckling Pin:** 304 Stainless Steel. Buckling pin is usually located outside of process stream. Contact factory for "special" material pin availability.

**Seal Material:** Viton®, Neoprene, Buna-N, EPDM, Kalrez®, and Chemraz®, and Viton® Extreme (subject to availability).

**Sizes Available:** 2" (50mm DIN) through 24" (600mm DIN).

**Set Point Range:** Pressure settings from 0.75 PSIG to 15 PSIG.

**Testing / Certification:** Each unit is factory tested for leakage and correct setting to meet Protectoseal's high quality standards. The Series 56000 provides bubble-tight sealing to set point as standard with optional testing and certification for <500 ppm leakage. For extremely low ppm leakage units, please contact factory and request information.

PIN-TECH vents have passed stringent testing through the United States Environmental Protection Agency's (EPA), Environmental Technology Verification (ETV) Program.

**Sizing & Flow Capacity:** Series No. 56000 PIN-TECH Pressure Relief Vents provide full open flow at the point of relief. To determine flow capacity and correct size for your application, follow the steps detailed on page 3.

**Flange Connections:** All sizes mate with standard flanged 150# ANSI, API (20" or 24" only) or DIN PN 16 connections.

**Instrumentation:** PIN-TECH units can be furnished with an optional lift indicator to detect when the vent has opened. Explosion Proof Class 1: Groups A, B, C & D / NEMA Groups 7 & 9. Mechanical indicator also available.

**Set Point Accuracy:** Set points are accurate to within +/- 5% across the entire range of available settings (0.75 PSIG through 15 PSIG). The repeatability of the set point for any specific vent configuration is assured by stringent machining, assembly and test procedures and by strict control of the metallurgy and dimensions of the buckling pin.

**Maintenance:** PIN-TECH Pressure Relief Vents are designed to minimize and simplify maintenance and inspection procedures. If the vent should open to relieve tank system pressure in excess of the set point, the buckling pin can be quickly and efficiently replaced to return the vent to its original, bubble-tight set point.

**Product Numbering System:** The Protectoseal Series 56000 PIN-TECH Pressure Relief Vent numbering system consists of twelve (12) alpha / numeric characters. Each digit represents a specific design option selected for a particular application. Please refer to Chart I on page 3.

### EXAMPLE:

Digit No.	1	2	3	4	5	6	7	8	9	10	11	12
Code	F	5	6	0	0	2	-	C	B	A	A	A

### Sizing Procedures

Series No. 56000 PIN-TECH Pressure Relief Vents provide full open flow at the point of relief. Follow the steps below to determine flow capacity and correct size for your application.

1. Calculate the tank's venting requirements in SCFH (standard cubic feet per hour of air) using NFPA 30, API 2000 or some other applicable criteria.
2. Determine the maximum pressure to which the tank or system is to be subjected. Note: The set point of the vent must be established at no more than 90% of the value chosen for the maximum pressure to which the tank or system is to be subjected.
3. Calculate the effective PIN-TECH sizing factor ( $K_{eff}$ ) using the following formula:

$$K_{eff} = \frac{CFH}{\sqrt{P}}$$

Where: CFH = Tank's venting requirement  
 P = Maximum pressure that the tank is to be subjected to, in inches of water column

$K_{eff}$  = Calculated number for the effective sizing factor

4. Compare the calculated  $K_{eff}$  to the K-Value listed below. Choose the vent size with a K-Value equal to or greater than the calculated  $K_{eff}$  factor.

K-Value	Size	K-Value	Size
4,250	2"	96,000	10"
9,800	3"	113,500	12"
16,180	4"	145,970	16"
36,200	6"	254,550	20"
62,050	8"	354,170	24"

5. Having identified the set point (Step #2) and the vent size (Step #4) proceed to Chart I to determine the correct Series 56000 PIN-TECH Pressure Relief Vent part number.

### Chart I - Part Numbering System

Digit	Designation	Option Code	Specification
1	Material	F	All Stainless Steel
		C	Stainless Steel with Steel Flange & Hood
		H	All Alloy C / C276
		A	Stainless Steel with Steel Flange & Aluminum Hood
2, 3, 4	Series No.	560	Series No.
5, 6	Size	02	2" / (50 mm DIN)
		03	3" / (80 mm DIN)
		04	4" / (100 mm DIN)
		06	6" / (150 mm DIN)
		08	8" / (200 mm DIN)
		10	10" / (250 mm DIN)
		12	12" / (300 mm DIN)
		16	16" / (400 mm DIN)
		20	20" / (500 mm DIN)
		24	24" / (600 mm DIN)
7	-	-	-
8	Vent Configuration	C	Reference Chart II
		D	Reference Chart II
9	Certification	A	Standard Bubble-Tight Test
		B	<500 ppm Test
10	Materials/Seals	A	Viton®
		B	Neoprene
		C	Buna-N
		D	EPDM
		E	Kalrez®
		F	Chemraz®
		(Check for availability) G	Viton® Extreme
11	Flange Connection	A	150# ANSI
		B	API (20" or 24" only)
		C	DIN PN 16
12	Instrumentation	A	None
		B	Explosion Proof, Class 1: A, B, C & D / NEMA 7 & 9
		C	Mechanical Indicator

### Chart II - Set Point Range / Vent Configuration

To determine the proper vent configuration: 1) locate the size (Step #4 of the Sizing Procedures) in the chart below; 2) find the desired set point range for that size; 3) identify vent configuration C or D at the top of the column.

Size	SET POINT RANGE	
	C	D
2"	N/A	8.5 PSIG incl. 15.0 PSIG
3"	N/A	3.5 PSIG incl. 15.0 PSIG
4"	N/A	2.0 PSIG incl. 15.0 PSIG
6"	0.75 PSIG up to 2.0 PSIG	2.0 PSIG incl. 15.0 PSIG
8"	0.5 PSIG up to 1.5 PSIG	1.5 PSIG incl. 15.0 PSIG
10"	0.375 PSIG up to 1.0 PSIG	1.0 PSIG incl. 15.0 PSIG
12"	0.375 PSIG up to 0.75 PSIG	0.75 PSIG incl. 15.0 PSIG
16"	0.375 PSIG up to 0.687 PSIG	0.687 PSIG incl. 15.0 PSIG
20"	0.375 PSIG up to 0.5 PSIG	0.5 PSIG incl. 15.0 PSIG
24"	0.312 PSIG up to 0.437 PSIG	0.437 PSIG incl. 15.0 PSIG

Note: Maximum setting in each configuration covers up to and including that setting.

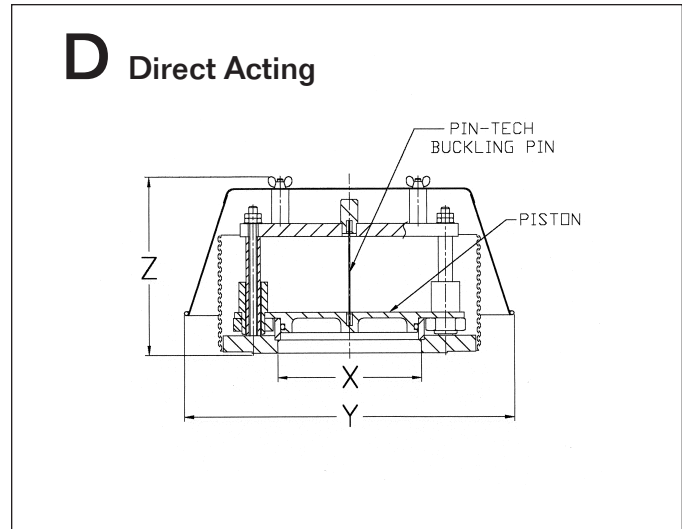
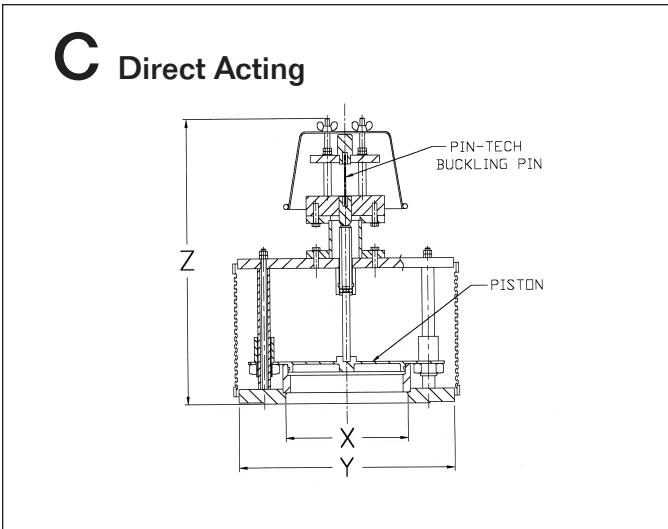

### Dimensions

X Size	C		D	
	Y Diameter	Z Height	Y Diameter	Z Height
2"	N/A	N/A	9 <sup>5</sup> / <sub>8</sub> "	7 <sup>1</sup> / <sub>8</sub> "
3"	N/A	N/A	14 <sup>1</sup> / <sub>8</sub> "	7 <sup>1</sup> / <sub>8</sub> "
4"	N/A	N/A	14 <sup>1</sup> / <sub>8</sub> "	7 <sup>1</sup> / <sub>8</sub> "
6"	11"	13 <sup>3</sup> / <sub>4</sub> "	14 <sup>3</sup> / <sub>8</sub> "	7 <sup>5</sup> / <sub>8</sub> "
8"	13 <sup>1</sup> / <sub>2</sub> "	13 <sup>3</sup> / <sub>4</sub> "	18 <sup>3</sup> / <sub>8</sub> "	7 <sup>3</sup> / <sub>4</sub> "
10"	16"	15 <sup>1</sup> / <sub>4</sub> "	20 <sup>3</sup> / <sub>8</sub> "	8 <sup>5</sup> / <sub>8</sub> "
12"	19"	16 <sup>3</sup> / <sub>8</sub> "	24 <sup>7</sup> / <sub>8</sub> "	9 <sup>1</sup> / <sub>8</sub> "
16"	23 <sup>1</sup> / <sub>2</sub> "	22 <sup>1</sup> / <sub>2</sub> "	27 <sup>5</sup> / <sub>8</sub> "	15"
20" ASA	27 <sup>1</sup> / <sub>2</sub> "	25"	33 <sup>5</sup> / <sub>8</sub> "	16 <sup>5</sup> / <sub>8</sub> "
20" API	26"	25"	33 <sup>5</sup> / <sub>8</sub> "	16 <sup>5</sup> / <sub>8</sub> "
24" ASA	32"	26 <sup>1</sup> / <sub>2</sub> "	41 <sup>3</sup> / <sub>8</sub> "	17 <sup>1</sup> / <sub>8</sub> "
24" API	30"	26 <sup>1</sup> / <sub>2</sub> "	41 <sup>3</sup> / <sub>8</sub> "	17 <sup>1</sup> / <sub>8</sub> "

Note: Viton® and Kalrez are registered trademarks of E.I. DuPont de Nemours Co., Inc. Chemraz® is a registered trademark of Green, Tweed & Co., Inc.



225 Foster Ave., Bensenville, IL 60106-1690  
 P 630.595.0800 F 630.595.8059  
 info@protectoseal.com www.protectoseal.com